

# Bidirectional AC-DC Microgrid system with Distributed Energy Resources: A Review

Anjana Verma, Dr. Manju Khare

M. Tech. Scholar, Head of Dept. (LNCT)

Lakshmi Narain College of Technology Excellence, Bhopal

**Abstract**— This paper studied to investigate energy management of the hybrid AC/DC microgrid with the high penetration of distributed energy resources (DERs), such as electrical vehicles, heat pumps, and photovoltaics. In the previous studies, energy management of the hybrid microgrid is usually carried out by the system operator in a centralized manner, which suffers from the compromise of privacy information protection and the risk of single-point failure. AC subgrid and DC subgrid, to make day-ahead schedules independently with information exchanges while obtaining the optimal energy management solution. The energy management problem of the hybrid microgrid is formulated as a mixed-integer quadratic programming (MIQP) model, considering DER and energy storage system operation constraints, system operation constraints, and converter operation constraints.

**Keywords:** - PV Array, Wind Power, Micro-grid, Distributed Energy Resources

## I. INTRODUCTION

The next-generation distribution system involves the massive deployment of distributed energy resources (DERs), such as electrical vehicles (EVs), heat pumps (HPs), and photovoltaics (PVs) [1]. Adopting the microgrid concept (a small-scale autonomous energy system) has become an effective and promising technology for the integration of DERs due to its technical and economic benefits including the lower operation cost, higher reliability, and stronger resiliency [2].

Generally, microgrids can be put into three main categories according to the voltage type: (1) AC microgrids, (2) DC microgrids, and (3) hybrid AC/DC microgrids [3]. The hybrid AC/DC microgrid separates the AC and DC power supplies and loads, with the AC bus and DC bus linked through a bidirectional converter (BC) [4]. Compared with the conventional AC microgrid requiring a number of AC/DC converters to convert power, the hybrid AC/DC microgrid has the lower equipment investment and can reduce the energy loss during power conversion. Therefore, the hybrid AC/DC microgrid has been considered as an important type of microgrids as more DC power sources and loads are connected [5].

Although the utilization of the microgrid brings about technical and economic benefits, there exist challenges on the microgrid operation, such as energy management. Energy management refers to the optimized operation of dispatchable resources within microgrids such as controllable generation units and loads in order to realize the best tech-economic operation of the microgrid based on system information and forecast data [6].

Energy management for AC or DC microgrids has been widely studied. In [6], a double-layer coordinated energy management approach was proposed for microgrids considering grid-connected and islanding modes, which consists of two layers: the schedule layer obtains an economic operation scheme based on forecast data, while the dispatch layer dispatches controllable units based on real-time data. A centralized optimal microgrid scheduling model which considers multiperiod islanding constraints was proposed in [7]. The optimal scheduling model is solved using the bender decomposition technique, and the obtained solution ensures the microgrid has sufficient capacity to switch to the islanded mode if needed by examining the solution with a proposed islanding criterion. In [8], a practical energy management model for microgrids which considers the operational constraints of DERs, active-reactive power balance, unbalanced system configuration, and voltage-dependent loads was formulated. Moreover, a novel linearization approach was used to reduce the computation complexity. In [9], a model predictive control-based microgrid energy management framework was proposed, which considers the demand response in smart loads and models power flow and unit commitment constraints simultaneously. A multiobjective optimal scheduling model for a DC microgrid considering PVs and EVs was formulated in [10] and solved by the NSGA-II algorithm. In [11], energy management of a DC microgrid with energy storage systems (ESSs) and EVs was studied. Moreover, the uncertainty of renewable energy resources was widely studied and modeled in the microgrid energy management problem in [12–14].

For hybrid AC/DC microgrids, the energy management problem of the hybrid microgrid was modeled in [14] considering multiple distributed ESSs. In [15], a decentralized power sharing method was proposed to share

power demands between the AC and DC sources without requiring communication between power sources. A temporally coordinated energy management strategy for the hybrid microgrid was proposed in [16] to deal with uncertainties of the RESs, loads, and converters while considering the dynamic conversion efficiency model of the converter. A two-stage min-max-min robust optimal energy management for the hybrid microgrid was proposed in [17] to deal with the uncertainties of generation sources and loads. An up-down energy management scheme of the hybrid microgrid was proposed in [18], which consists of two levels: the generation and load balance are realized at the system level, while power converter-based resources are used to control the voltage variations at the device level. However, energy management of the hybrid microgrid in the aforementioned studies is carried out by the system operator in a centralized manner, which suffers from the compromise of privacy information protection and single-point failure risk.

## II. MICROGRID STRUCTURE

Microgrid solar PV and wind generation system become very attractive solution in particular for stand-alone applications. Combining the two sources of solar and wind can provide better reliability and their hybrid system becomes more economical to run since the weakness of one system can be complemented by the strength of the other one. The integration of hybrid solar and wind power systems into the grid can further help in improving the overall economy and reliability of renewable power generation to supply its load. Similarly, the integration of hybrid solar and wind power in a stand-alone system can reduce the size of energy storage needed to supply continuous power. Solar electricity generation systems use either photovoltaics or concentrated solar power. The focus in this paper will be on the photovoltaics type. Detailed descriptions of the different technologies, physics and basics of PV can be found in many textbooks and papers such as [4-7]. Kurtz [8] pointed out that ten years ago the concentrator cell was only ~30% efficient compared with more than 40% today with the potential to approach 50% in the coming years. Si cells have efficiencies of 26% and multi-junction III-V-compound cells have efficiencies above 45% (48% in the laboratory) as pointed out in reference [9]. PV modules produce outputs that are determined mainly by the level of incident radiation. As the light intensity increases, photocurrent will be increased and the open-circuit voltage will be reduced [10]. The efficiency of any photovoltaic cell decreases with the increasing temperature which is non-uniformly distributed across the cell [11]. The solar output power can be smoothed by the distribution of solar power in different geographical areas [12]. Electricity from solar PV and concentrated solar power plants is significantly expensive and requires significant drop in cost or change in policies by either subsidizing or forcing the use of these technologies to be able to achieve significant market penetration [13]. Global wind report (2012) indicated that the annual market grew by around 10% to reach around 45 GW and the cumulative market growth was almost 19% [14]. Detailed descriptions of the wind energy can be found in references [4] and [15]. Wind turbines (WTs) are classified into two types: horizontal-axis WT (HAWT) and vertical-axis WT (VAWT). The highest achievable extraction of power by a WT is 59% of the total theoretical wind power [15]. Hybrid solar-wind systems can be classified into two types: grid connected and stand-alone. Literature reviews for hybrid grid connected and stand-alone solar PV and wind energies were conducted worldwide by many researchers who have presented various challenges and proposed several possible solutions. Due to the nature of hybrid solar PV and wind energies, optimization techniques can play a good role in utilizing them efficiently. Graphic construction methods [16], linear programming [17-18], and probabilistic approach [19] are few examples of optimization techniques that have been developed for techno-economically optimum hybrid renewable energy system for both types. Luna-Rubio et al. [20] conducted a review of existing research of optimal sizing of renewable hybrids energy systems with energy storage components for both stand-alone and grid-connected systems. The authors gave brief descriptions about those indicators and the different sizing methods. A review of control strategies for a hybrid renewable energy system was carried out in [21] and another review was done in [22] for optimization of hybrid renewable energy system with more focus on wind and solar PV systems. The reviews in [21] and [22] are applicable for both types; grid-connected and stand-alone systems.

## III. CONTROL OF MICROGRID

The control strategies for microgrid depend on the mode of its operation. The aim of control technique should be to stabilize the operation of microgrid. When designing a controller, operation mode of MG plays a vital role. Therefore, after modelling the key aspect of the microgrid is control.

### 1. Control of Grid Connected

In grid connected mode, microgrid acts as a controllable load/source. It should not actively regulate the voltage at the point of common coupling (PCC). Its main function is to satisfy its load requirements with good citizen behavior towards main grid. The balance between generation and demand, control of the parameters of the

system is taken care by the utility grid. The voltage and frequency reference of the microgrid is also set by the main grid. Therefore the main task of a DG unit is to control the output real power ( $P$ ) and reactive power ( $Q$ ).

## 2. Control Islanded Microgrid

In islanded mode, the reactive power sharing is highly dependent on impedance of power line. Due to the different distances among DERs interface converters (DICs), the equivalent transmission line impedance could be unequal [51].  $Pf$  and  $QV$  droop characteristics are used in DER interface converters for power sharing operations. The  $Pf$  droop control provides an accurate real power sharing among the DIC's but the problem arises in  $QV$  droop control. Because of this unequal impedance load sharing performance of  $QV$  control can be affected.

## IV. GRID CONNECTED SYSTEM

The integration of combined solar and wind power systems into the grid can help in reducing the overall cost and improving reliability of renewable power generation to supply its load. The grid takes excess renewable power from renewable energy site and supplies power to the site's loads when required. Fig. 1 and Fig. 2 show the common DC and common AC bus grid-connected to solar PV and wind hybrid system, respectively

### Power electronics topologies and control

There are two topologies for grid-connected solar PV and wind hybrid system as can be seen from Fig. 1 and Fig. 2. Fig. 1 shows that the DC outputs' voltages from individual solar PV, wind and battery bank stream, through individual DC/DC and AC/DC units, are integrated on the DC side and go through one common DC/AC inverter which acts as an interface between the power sources and the grid to provide the desired power even with only one source available. Hence, the renewable energy sources act as current sources and can exchange power with the grid and the common DC/AC inverter controls the DC bus voltage. The individual units can be employed for maximum power point tracking (MPPT) systems to have the maximum power from the solar PV and wind systems and the common DC/AC inverter will control the DC bus voltage.

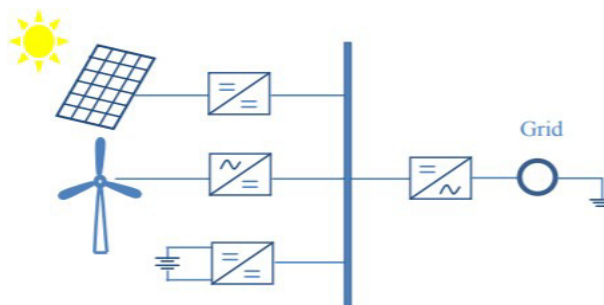

Figure 1: Grid-connected hybrid system at common DC bus

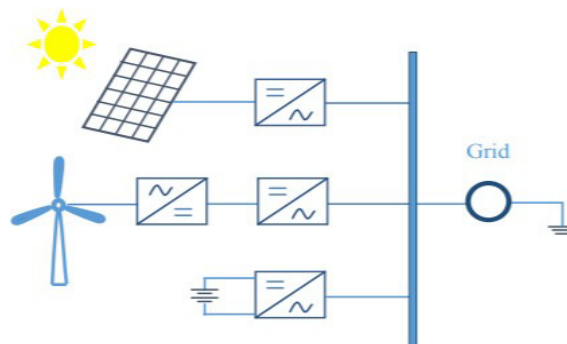

Figure 2: Grid-connected hybrid system at common AC bus

The battery bank is charged when there is an extra power and discharged (by supplying power) when there is shortage of power from the renewable energy sources. On the other hand, Fig. 2 shows that renewable energy sources are injecting power directly to the grid through individual DC/AC and AC/DC-DC/AC units.

### Power quality

The increased penetration of grid-connected renewable energy sources has an impact on the grid power quality in particular weak grids. Voltage fluctuation, frequency fluctuation and harmonics are major power quality issues. Furthermore, intermittent energy from solar PV and wind has a huge impact on network reliability.

However, accurate forecasting and scheduling systems can minimize the impacts. Various statistical forecasting and regression analysis approaches and algorithms are used to forecast weather pattern, solar radiation and wind speed [12-13]. System operator can adjust other dispatch able generation elsewhere in a system to deal with any deficit or surplus power from renewable power generation [14]. This will reduce the impact of the fluctuations from the generation of the renewable energy sources. In addition, the distribution of RES to larger geographical area in small units instead of large unit concentrating in one area can control the intermittence effect of power generation from RES [15]. Energy storage devices like batteries or Uninterruptable Power Supply (UPS) can work as a balancing devices that provide power when there is an energy deficiency in renewable generation and store excess energy when there is surplus power from renewable generation [16-17]. Active power filters such as dynamic voltage regulators, static synchronous compensators and unified power quality conditioners can be used to resolve voltage fluctuation [18], [19]. Similarly, power compensators such as fixed or switched capacitor can be used to resolve reactive power issue [20]. They are the latest interfacing devices between grids and consumer appliances. Sudden changes in active power drawn by a load could cause system frequency fluctuation in AC grids. These changes represent unbalance situations between load and generation. In view of the above, it is important to design control loops for power and frequency control to mitigate quality issues [21]. Bae and Kwasinski highlighted that a primary goal of a pulse width modulation (PWM) inverter controller was to regulate three-phase local AC bus voltage and frequency in a microgrid. Harmonics are normally caused by power electronics devices and non-linear appliances. Appropriate filters and PWM switching converter can be used to mitigate harmonic's distortion.

### Optimization

As mentioned earlier, a combination of solar PV and wind sources improves overall energy output. However, energy storage system is required to have a continuous power supply and cover any deficiency in power generation from the renewable energy sources. The storage system can be battery banks, fuel cells, etc. with a more focus here on battery banks. Various optimization techniques have been reported which could be applied to reach a techno-economically optimum hybrid renewable energy system [16-19]. A comparison was made for many optimization techniques of hybrid systems in [18]. For remote areas which represent most of the standalone application for hybrid solar PV and wind systems, it is not always easy to find long-term weather data, such as solar radiation and wind speed that are used for sizing purposes. Hence, more artificial intelligence techniques such as fuzzy logic, genetic algorithms and artificial neural network are used for sizing standalone systems in comparison with traditional sizing method based on long-term weather data.

### Wind Energy Systems

Wind energy has the biggest share in the renewable energy sector [1], [3]. Over the past 20 years, grid connected wind capacity has more than doubled and the cost of power generated from wind energy based systems has reduced to one-sixth of the corresponding value in the early 1980s [3]. The important features associated with a wind energy conversion system are:

- Available wind energy
- Type of wind turbine employed
- Type of electric generator and power electronic circuitry employed for interfacing with the grid.

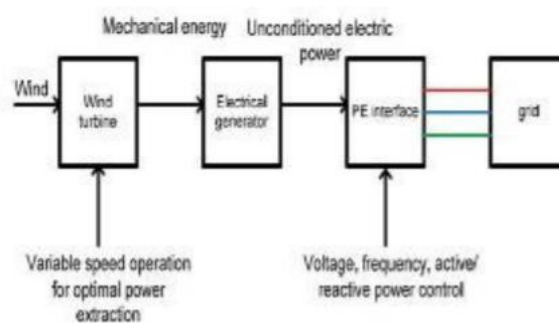

Figure 3: Variable speed wind energy conversion system

Wind energy – Wind speeds, air pressure, atmospheric temperature, earth surface temperature etc., are highly inter- linked parameters. Due to the inherent complexity, it is unrealistic to expect an exact physics based prediction methodology for wind intensity/sustainability. However, distribution based models have been proposed, and employed to predict the sustainability of wind energy conversion systems [4]. Detailed

explanation of the wind energy resources is beyond the scope of this paper. Based on studies it has been reported that the variation of the mean output power from a 20 year period to the next has a standard deviation of less than 0.1 [4]. It can be concluded with reasonable confidence that wind energy is a dependable source of clean energy. Based on the aerodynamic principle utilized, wind turbines are classified into drag based and lift based turbines. Based on the mechanical structure, they are classified into horizontal axis and vertical axis wind turbines. With respect to the rotation of the rotor, wind turbines are classified into fixed speed and variable speed turbines. Presently the focus is on horizontal axis, lift based variable speed wind turbines [2], [3]. Power electronic circuits play a crucial enabling role in variable speed based wind energy conversion systems. Fixed speed wind turbines are simple to operate, reliable and robust. However the speed of the rotor is fixed by the grid frequency. As result, they cannot follow the optimal aerodynamic efficiency point. In case of varying wind speeds, fixed speed wind turbines cannot trace the optimal power extraction point. In variable speed wind turbines, power electronic circuitry partially or completely decouples the rotor mechanical frequency from the grid electrical frequency, enabling the variable speed operation. The type of electric generator employed and the grid conditions dictate the requirements of the power electronic (PE) interface. Fig. 1 depicts a variable speed wind energy conversion system. The electrical generator popularly employed for partially variable speed wind energy conversion systems are doubly-fed induction generators [5]. Fig. 2 depicts a doubly-fed induction-generator where the rotor circuit is controlled by the power converter system via the slip rings and the stator circuit is connected to the grid. This method is advantageous as the power converter has to handle a fraction ~ 25% - 50 % of the total power of the system [5]. The power converter system employs a rotor side ac-dc converter, a dc link capacitor, and a dc-ac inverter connected to the grid as shown in Fig.

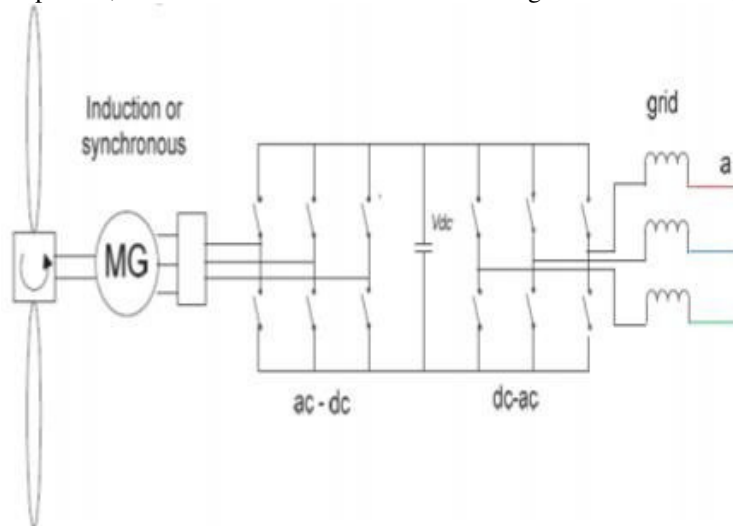

Figure 4: Fully variable wind energy conversion system

## V. BIDIRECTIONAL AC-DC MICROGRID SYSTEM

Power architecture of microgrid is classified based on the arrangement of the power converter. The major classification includes centralized and distributed power architecture.

### Centralized power architecture

The centralized power architecture constitutes a power electronic converter as a central hub. The centralized power converter module and its control unit processes and delivers the power to multiple loads connected. A simple block diagram of centralized power architecture in a microgrid is as shown in Fig. 5.

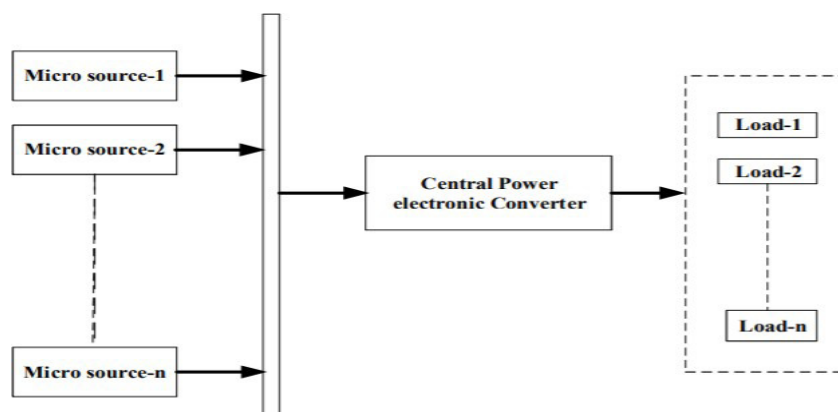

Fig. 5: Centralized power architecture in islanded microgrid

The major issues concerned about the centralized power architecture of microgrid include interruption of power supply, failure in power supply since the power-processing technology is concentrated in a single system.

### **Distributed power architecture**

The major disadvantage of centralized power architecture can be overcome by the distributed power architecture. The distributed structure comprises of modules of low power electronic interface instead of a single high-power electronic converter. The power electronic converters (PEC) at the low power level have to be interconnected in parallel either at the front end or at the load end to deliver the expected output (Luo et.al., 1999). The interconnected power electronic modules distributed power architecture is characterized by

**Modularity:** Instead of utilizing a single power module, the distributed power structure uses a multiple low power module. This feature adds up the advantage of uninterruptible power to load.

**Size and setup:** Since modular low power electronic interface operates at high switching frequencies, the power density of the system can be increased and the size of the auxiliary component like filters can be decreased. Overall system sizing will be reduced, and system setup would be feasible.

**Power Quality:** The power quality features like ripple content, harmonics, Electromagnetic interference is reduced. This is due to the fact that the aggregated output of the interconnected converter produces low energy density spectrum that reduces the harmonic components as well as the interference.

**Reliability:** The Electrical and thermal stress of the system is distributed on numerous power converter modules with a lower rating. Also, the capability of the low power converter to operate at high switching frequency will increase the control bandwidth of the converter. Hence the response time of parallel-connected system will be much lower under abnormal conditions. This tends to augment a simple fact that as the number of modules in a parallel structure increase, the overall reliability of the system will also increase.

**Redundancy:** The feature corresponds to the utilization of superfluous modules of the converter. The redundant characteristic of the distributed power architecture helps to improve reliability by improving the tolerance towards the failure of the additional power modules. The prospect of redundancy is most useful in certain application like telecom and aerospace applications.

**Maintenance:** The maintenance prospect involves the repair of a redundant module of the distributed parallel system. The replacement of the defective modules of the system can be done through online health monitoring of the system. This assures easy and uninterrupted maintenance.

**Regulation:** The proximity of the load and the generation system facilitates improved regulation and dynamic response of the system. The point of load converters expects to realize the control aspect in a challenging environment.

**Flexibility in the system:** To cater to different load requirements, the distributed power architecture is more suitable. This is made possible by a different type of interconnection of the power modules.

## **VI. CONCLUSION**

To resolve the privacy information protection compromise and single-point failure issues when the centralized energy management scheme is applied, this paper studied a distributed energy management scheme for the hybrid AC/DC microgrid. The energy management problem of the hybrid microgrid is formulated as a MIQP model, considering DER operation constraints, system operation constraints, and converter operation constraints. Then, the MIQP model is decomposed and distributed into smaller-scale submodels between subgrids.

## **REFERENCES**

- [1] M. Abarzadeh and K. Al-Haddad, "An improved active-neutral-point-clamped converter with new modulation method for ground power unit application," *IEEE Trans. Ind. Electron.*, vol. 66, no. 1, pp. 203–214, Jan. 2019.
- [2] Y. P. Siwakoti, "A new six-switch five-level boost-active neutral point clamped (5L-Boost-ANPC) inverter," in *Proc. IEEE Appl. Power Electron. Conf. Expo.*, 2018, pp. 2424–2430.
- [3] A. K. Yadav, M. Boby, S. K. Pramanick, K. Gopakumar, L. Umanand, and L. G. Franquelo, "Generation of high-

- resolution 12-sided voltage space vector structure using low-voltage stacked and cascaded basic inverter cells," *IEEE Trans. Power Electron.*, vol. 33, no. 9, pp. 7349–7358, Sep. 2018.
- [4] W. Li, J. Hu, S. Hu, H. Yang, H. Yang, and X. He, "Capacitor voltage balance control of five-level modular composited converter with hybrid space vector modulation," *IEEE Trans. Power Electron.*, vol. 33, no. 7, pp. 5629–5640, Jul. 2018.
- [5] D. Cui and Q. Ge, "A novel hybrid voltage balance method for five-level diode-clamped converters," *IEEE Trans. Ind. Electron.*, vol. 65, no. 8, pp. 6020–6031, Aug. 2018.
- [6] W. Sheng and Q. Ge, "A novel seven-level ANPC converter topology and its commutating strategies," *IEEE Trans. Power Electron.*, vol. 33, no. 9, pp. 7496–7509, Sep. 2018.
- [7] H. Tian, Y. Li, and Y. W. Li, "A novel seven-level-hybrid clamped (HC) topology for medium-voltage motor drives," *IEEE Trans. Power Electron.*, vol. 33, no. 7, pp. 5543–5547, Jul. 2018.
- [8] Y. P. Siwakoti and F. Blaabjerg, "Common-ground-type transformerless inverters for single-phase solar photovoltaic systems," *IEEE Trans. Ind. Electron.*, vol. 65, no. 3, pp. 2100–2111, Mar. 2018.
- [9] N. D. Dao and D.-C. Lee, "Operation and control scheme of a five-level hybrid inverter for medium-voltage motor drives," *IEEE Trans. Power Electron.*, vol. 33, no. 12, pp. 10178–10187, Dec. 2018.
- [10] H. Wang, L. Kou, Y.-F. Liu, and P. C. Sen, "A seven-switch five-level active-neutral-point-clamped converter and its optimal modulation strategy," *IEEE Trans. Power Electron.*, vol. 32, no. 7, pp. 5146–5161, Jul. 2017.
- [11] J. Rodríguez, S. Bernet, B. Wu, J. O. Pontt, and S. Kouro, "Multilevel voltage-source-converter topologies for industrial medium-voltage drives," *IEEE Trans. Ind. Electron.*, vol. 54, no. 6, pp. 2930–2945, Dec. 2007.
- [12] F. Z. Peng, "A generalized multilevel inverter topology with self-voltage balancing," *IEEE Trans. Ind. Electron.*, vol. 37, no. 2, pp. 611–618, Feb. 2001.
- [13] F. Rong X. Gong and S. Huang "A novel grid-connected PV system based on MMC to get the maximum power under partial shading conditions" *IEEE Trans. Power Electron.* vol. 32 no. 6 pp. 4320-4333 Jun. 2017.
- [14] H. Wang, L. Kou, Y.-F. Liu, and P. C. Sen, "A seven-switch five-level active-neutral-point-clamped converter and its optimal modulation strategy," *IEEE Trans. Power Electron.*, vol. 32, no. 7, pp. 5146–5161, Jul. 2017.
- [15] G. Farivar B. Hredzak and V. G. Agelidis "A dc-side sensorless cascaded H-bridge multilevel converter-based photovoltaic system" *IEEE Trans. Ind. Electron.* vol. 63 no. 7 pp. 4233-4241 Jul. 2016.
- [16] Y. Yu G. Konstantinou B. Hredzak and V. G. Agelidis "Power balance of cascaded H-bridge multilevel converters for large-scale photovoltaic integration" *IEEE Trans. Power Electron.* vol. 31 no. 1 pp. 292-303 Jan. 2016.
- [17] J. I. Leon S. Kouro L. G. Franquelo J. Rodriguez and B. Wu "The essential role and the continuous evolution of modulation techniques for voltage-source inverters in the past present and future power electronics" *IEEE Trans. Ind. Electron.* vol. 63 no. 5 pp. 2688-2701 May 2016.
- [18] Y. Yu G. Konstantinou B. Hredzak and V. G. Agelidis "Operation of cascaded H-bridge multilevel converters for large-scale photovoltaic power plants under bridge failures" *IEEE Trans. Ind. Electron.* vol. 62 no. 11 pp. 7228-7236 Nov. 2015.
- [19] H. Snani M. Amarouayache A. Bouzid A. Lashab and H. Bounechba "A study of dynamic behaviour performance of DC/DC boost converter used in the photovoltaic system" *Proc. IEEE 15th Int. Conf. Environ. Elect. Eng.* pp. 1966-1971 2015.
- [20] Bayhan, S & Abu-Rub, H 2015, 'Model predictive control of quasi-z source three-phase four-leg inverter', in 41st Annual Conference of the IEEE Industrial Electronics Society, IECON 2015, pp. 362-367.
- [21] R. J. Wai, C. Y. Lin, C. Y. Lin, R. Y. Ouan, and Y. R. Chang, "High efficiency power conversion system for kilowatt-level stand-alone generation unit with low input voltage," *IEEE Trans. Ind. Electron.* vol. 55, no. 10, pp. 3702–3714, Oct. 2008.