

# SIMULATION AND ANALYSIS OF PI CONTROLLER BASED BLDC MOTOR IN ELECTRIC VEHICLE APPLICATION USING MATLAB

Md. Atif Alim<sup>1\*</sup>, Prakhar Singh Bhadoria<sup>2</sup>

Research Scholar, Department of Electrical & Electronics Engineering, Lakshmi Narain College of Technology & Excellence, Bhopal<sup>1</sup>

Assistant Professor, Department of Electrical Engineering, Lakshmi Narain College of Technology, Bhopal<sup>2</sup>

## Abstract

*This paper deals with the performance of electric vehicle. In this paper, performance of 2 kW BLDC motor used in electric vehicle is observed. This paper explain the PI controller based controlling of electric vehicle in simulation load condition and parameters like voltage, current, charging and discharging of battery are observed. The prime objective of this paper is to highlight the engineering and designing processes that were followed for developing an E-KART vehicle. This paper explains controlling, approach, reasons, selecting criteria and expected working of the electric parameters with primary objective is to design and manufacture a safe and efficiently functioning of electric vehicle system which is comfortable and sufficiently durable with the underlying motive of fabricating a prototype vehicle that could be. So in this paper, simulation of PI controller for electric kart is observed in MATLAB software.*

## Keywords

*Battery Energy Storage System, Brushless DC motor, Electric Vehicle, Hybrid Electric Vehicle.*

## 1.Introduction

It is a challenge today to find the best alternative for road transportation due to continuous decay of fuels. Also it is important to find the alternative for the continuous emission of toxin and harmful green house gases which effect or environment to a large extent. So for solution to this problem Electric vehicle comes to an existence with a good solution for all these issues. Electric vehicle (EV) is a road vehicle which involves with electric propulsion. With this broad definition in mind, electric vehicles may include battery electric vehicles (BEV), hybrid electric vehicle (HEV) and fuel cell electric vehicle (FCEV). In this BEV's offer high powertrain efficiency and no harmful gases, that's why, it is considered CO<sub>2</sub> neutral in the regulation [1]. If charged with electricity that is produced by the fossil free and renewable sources, BEV's have the potential to offer an emission free use phase [2]. In today's

market, manufacturers are developing their own technologies for designing of Electric Vehicle. Annual growth rate of EV is increased to 54%-87% during 2012-2014 [3]. The major drawback of EV is battery backup i.e charging and discharging of battery which makes a tough competition between various manufacturers. This factor makes the competition of EV with the fuel used vehicles [4] [5]. But with the changes in time, In last few years the price of Lithium batteries has dropped upto 80% with the increase in efficiency [6] [7]. Electric vehicle is a multi-disciplinary subject which covers broad and complex aspects. However, it has core technologies, namely chassis and body technology, propulsion technology and energy source technology. Initially all the possible alternatives for a system and chassis design were considered and modeled using CAD software (SOLIDWORKS, FUSION 360 etc). These designs were subsequently subjected to analysis using FUSION 360 software. Based on the static and dynamic analysis results, the modeled and designed elements were rectified which led to a final design being chosen. The designing process had the following objectives: Safety, Ergonomics and Ruggedness; while not compromising on performance.

An electric vehicle (EV) is also one that operates on an electric motor, instead of an internal-combustion engine that generates power by burning a mix of fuel and gases. Therefore, such as vehicle is seen as a possible replacement for current-generation automobile, in order to address the issue of rising pollution, global warming, depleting natural resources, etc. Though the concept of electric vehicles has been around for a long time, it has drawn a considerable amount of interest in the past decade amid a rising carbon footprint and other environmental impacts of fuel-based vehicles. Fig. 1 shows the schematic sketch for electric vehicle which shows the main parts of electric vehicle like Battery, power controller, electric motor, speed gear and

driving wheel. In fig. 1, it is seen that, battery supplies the controller, so that the motor operates smoothly from zero to full speed without any complications. This motor is connected to the gear system of the driving wheel which run the electric vehicle with better speed and improved efficiency.

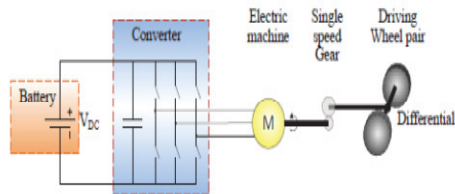

Fig.1 Simple schematic sketch of BEV Powertrain

The maximum tractive force on the driving wheels can be limited by either the powertrain's maximum force capability or the maximum adhesive capability between tire and ground that is possible to be applied on the wheel without losing the grip to the road, i.e. starting to spin or slide [8].

### 1.1 Target Vehicle Performance

The expected target performance for our vehicle were determined while focusing on the following factors –

1. Driver safety
2. Adventurous ride and low cost
3. Track study
4. Easy manufacturing
5. Avoid over engineering
6. Pollution free

## 2. Design of Electric Vehicle:

### ELECTRICAL DESIGNING:

**Power Train:** The term Power train means (Battery + Motor), means a chain of the components who provide the power to the our vehicle,

Mainly there are three major components

1. Motor
2. Motor controller
3. Battery

**1. Motor:** A motor converts supplied electrical energy into mechanical energy. Various types of motors are in common use. As motor are power delivery machine.

**2. Motor Controller:** Motor controller is a device or group of devices that serves to govern in some predetermined manner the performance of an electric motor.

**3. Battery:** A battery is a device consisting of one or more electrochemical cell with external connections for delivering the electrical power to the machine

### Practical case:

We can't accelerate the kart in an instant as we have to protect controller from instantaneous current increase (di/dt protection) and slipping of tyres also have to be considered. So, considering this actual time to reach maximum speed would increase.

## 3. MATLAB Based Modelling:

The model of Electric Vehicle drive is divided into four parts, i) Motor Model, ii) Motor controller model, iii) Battery model & iv) PI controller model. Fig. 2 shows the DC drive simulation model of Electric vehicle.

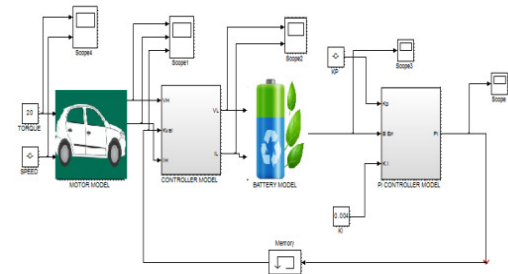

Fig.2 DC Drive Simulation Model

Fig. 3 shows the simulation model for BLDC motor. The motor model is designed using the following equations:

Developed torque is proportional to armature current:

$$T_d \text{ (Nm)} = K_m * I_a \text{ (Amp)} \dots\dots\dots (i)$$

Developed voltage is proportional to armature speed:

$$V_d \text{ (volt)} = W_d \text{ (rad/sec)} / K_m \dots\dots\dots (ii)$$

Therefore, motor terminal voltage is equal to the sum of the developed voltages and the voltage drops in the motor:

$$V_h \text{ (volt)} = I_h \text{ (amp)} * R_a \text{ (ohm)} + L_h \text{ (Henry)} * di(t)/dt \text{ (A/s)} + V_d \text{ (volt)} \dots\dots\dots (iii)$$

$K_m$ , is a motor physical constant whose physical parameters depends upon the construction.

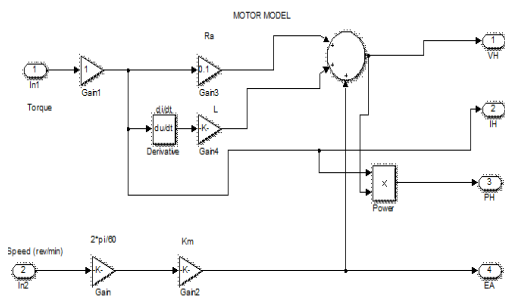

Fig. 3 Motor Model Block

The motor controller increases the battery voltage to meet the higher voltage need of the motor. The constant gain K is so adjusted so that the power at input and output is equal. So, Fig. 4 shows the simulation model for motor controller which is designed using equ. 4 & 5.

$$V_h = K * V_L \dots\dots\dots (iv)$$

$$I_h = (1/K) * V_L \dots\dots\dots (v)$$

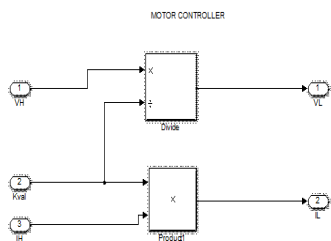

Fig. 4 Motor Controller Model Block

Fig. 5 shows the simulation model for battery, which is modelled as a voltage source with an internal resistance. The battery terminal voltage is equal to the sum of the internal voltage and resistance voltage drop. So fig. 5 will obtain from:  
 $V_B \text{ (volt)} = I_a \text{ (amp)} * R_a \text{ (ohm)} + E_B \text{ (volt)} \dots(vi)$

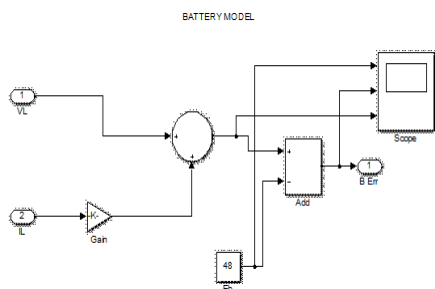

Fig. 5 Battery Model Block

Fig. 6 show the simulation model of proportional integral (PI) controller which accepts the battery error signal from battery and uses proportional gain (Kp) and integral gain (Ki) to calculate the gain K which is

further used by the motor controller. So fig. 6 can be obtained by using the given equation:

$$K = ((K_p + s * K_i) * B_{err} \dots\dots\dots (vii)$$

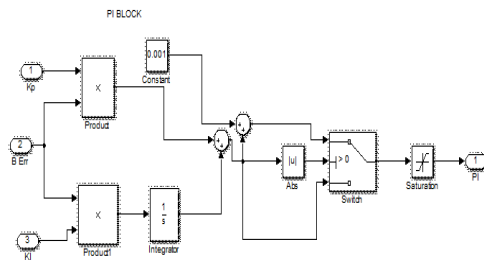

Fig. 6 PI Controller Model Block

**4. RESULTS AND DISCUSSION:**

Fig. 7 and fig. 8 shows the graph for Torque-Time and Speed-Time which gives the constant value through out the running.

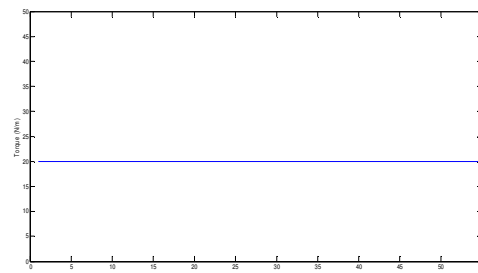

Fig. 7 Torque of Motor

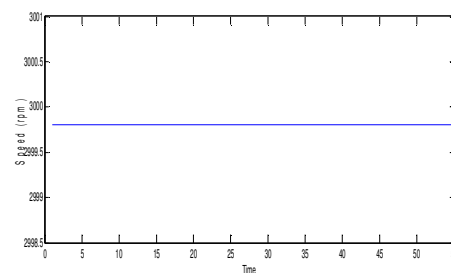

Fig. 8 Speed of Motor

Fig. 9, fig. 10 and fig. 11 shows the results for the voltage, current and power which is drawn from the battery to the motor. When voltage and current are both in positive direction, motor provide torque in the direction of rotation.

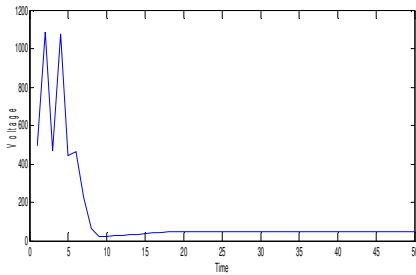

Fig. 9 Voltage across the Motor

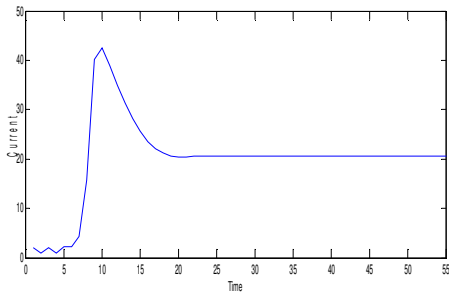

Fig. 10 Current across the Motor

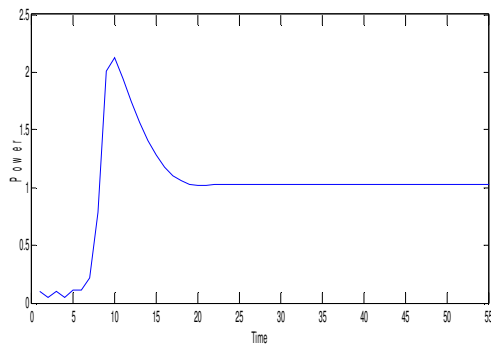

Fig. 11 Power across the Motor

Fig. 12 shows the plotting of battery error voltage. At the initial error goes to its peak value, but after adjusting the controller value the error from the battery goes to near zero. i.e the voltage at the initial is equal to the voltage across the load or motor. It is normal to have a higher error during starting, especially when the current is increasing.

$$V_d \text{ (volt)} = W_d \text{ (rad/sec)} / K_m$$

The negative error occurs during the regeneration.

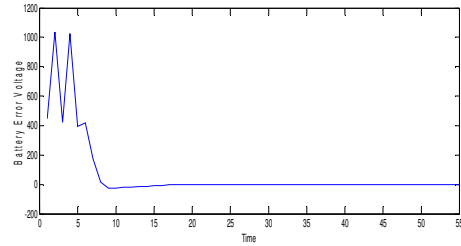

Fig. 12 Battery Error Voltage in volts

Fig. 13 shows the value of gain constant K, which can be determined from the output of the PI controller. The value of gain is directly proportional to speed of the motor, i.e K increases with increase in speed of the motor and vice-versa.

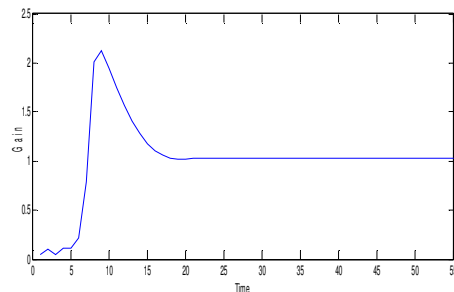

Fig. 13 Controller Gain K Value

### 5. Conclusion and future work:

The performance of the proposed design of electric vehicle give the best results using BLDC motor. The voltage, current, power, torque, speed generally gives the constant output from motor. Also the battery error voltage from the battery is also minimum. So this Electric Kart can be easily designed in the hardware for real time work. This vehicle gives the best results in the hardware designing..

### FUTURE SCOPE

- Design can be modified for commercial use and also by using more power motor.
- Design can be upgrade to Hybrid Electric vehicle for better performance.
- Diagnosis of faults of various elements like, motor faults, bearing faults, gear faults.

### References

#### Journal reference

- [1] (2012, may) Regulation no 101, official journal of European union. Economic Commission for Europe of the United Nations. Accessed 2012-10-31. [Online]. Available:

<http://eurlex.europa.eu/LexUriServ/lexuriServ.do/uri=OJ:L:2012:138:0001:0077:en:PDF>

Email: Aatif9113793909@gmail.com

- [2] Nordelof A., Messagie M., Tillman A.-M., Ljunggren Soderman M., and Van Mierlo J., "Enviromantal impacts of hydrod, plug-in hybrid, and battery electric vehicle- what can we learn from life cycle assessment?" The International Journal of life Cycle Assessment, 19(11) 1866-1890.
- [3] (2015) Global ev outlook 2015. IEA, International Energy Agency, EVI, Electric Vehicles Initiative. Accessed 2015-04-27. Available: <http://cleanenergyministerial.org/Portals/0/pdfs/EVI-globalEVO Outlook2015-v14-landscape.pdf>.
- [4] Mock P, European vehicle market statistics, 2014. The International Council of Clean Transportation (ICCT).
- [5] Rajashekhar K., "Present status and future trends in electric vehicle propulsion technologies," Emerging and Selected Topics in Power Electronics, IEEE, 2013 Journal of, 1(1) 3-10.
- [6] Messagie, M.; Boureima, F.-S.; Coosemans, T.; Macharis, C; van Mierlo, V.A Range-Based Vehicle Life Cycle assessment Incorporating Variability in the EnviromentalAssessment of Different Vehicle Technologies and Fuels. Energies 2014, 7, 1467-1482.
- [7] Hooftman, N.; Oliveira, L.; Messagie, M.; Coosemans, T.; Van Mierlo, J. Enviromental Analysis of Petrol, Diesel and Electric Passenger Cars in a Belgian Urban Setting. Energies 2016, 9, 84.
- [8] Singh B., Kasal G.K. and Gairola S., "Power Quality Improvement in Conventional Electronic Load Controller for an Isolated power.
- [9] Tech Imperial Your Vision Our Expertise, Specification of Various BLDC Motors, 2019.
- [10] Bhadoria P.S., Sharma R., Dubey R, "Study on Machinery Fault Diagnosis using Signal Processing Techniques", Journal of Emerging Technologies and Innovative Research (JETIR), 2019, 6(6), 247-250.
- [11] Bhadoria P.S., Sharma R., Dubey R, "Simulation and Design of Electric Kart using 2 Kw BLDC Motor", International Journal of Advanced Science & Technology, 2020, 29(5), 8859-8871.
- [12] Atif Md, Singh R, Bhadoria P.S, Asati N, "Present and Future Scenario in Electric Vehicles", Journal of Emerging Technologies and Innovative Research (JETIR), 2021, 8(12), a1-a5.



**Prakhar Singh Bhadoria**, He was born in Gwalior (M.P), India. He is currently pursuing Doctorate degree in Electronics & Communication Engineering from Amity University, Gwalior (M.P). He has completed his Masters in Power System in 2012 from Oriental Institute of Science & Technology, Bhopal (M.P) & Bachelor of Engineering, in 2008 in Electrical & Electronics Engineering, from Lakshmi Narain College of Technology, Bhopal (M.P). He has done research in various field of engineering. His major topic of research is Digital Signal Processing, Control System, Power Electronics, Energy, and Electric Vehicle. He is currently serving as Assistant Professor in Lakshmi Narain College of Technology in the department of Electrical & Electronics Engineering, Bhopal (M.P). He has publishes research papers in various national and international Journals, also presented his paper in various national & international conferences. He has also worked in designing and simulating the system using various softwares like, MATLAB, SCILab, DSpace, DSP trainer kit.  
Email: prakharb@lnct.ac.in



Md. Atif Alim, He was born in Munger (Bihar), India. He is currently pursuing Master of Technology Degree in Power System from Lakshmi Narain College of Technology & Excellence, Bhopal (M.P). He has completed his Bachelor of Engineering in 2018 in Electrical Engineering from Lakshmi Narain College of Technology, Bhopal (M.P). He has done work on Electric Motors, Electric Vehicles. He has published research paper in International Journal. He has worked on design and simulation in MATLAB.