

Mitigation of harmonics using PI controlled shunt active power filter

Md.Taslim Arif and Sujeet Kumar Soni

Electrical and Electronics Engineering , LNCT, Bhopal, India

Abstract

When using non linear loads, affects the quality of supply power ,which leads to a number of issues like harmonics, voltage sag, voltage swell, flicker, voltage imbalance etc. these issues affects the performance and the lifetime of the utilities. In order to overcome issues arises due to nonlinear loads power filters were developed. This work proposed a active filter which is controlled by PI controller to reduce the THD (total harmonic distortion). Here we compared the results of active filter results, without controller and with PI controller.

Keywords

Harmonic reduction, Active filter, PI controller, THD.

1.Introduction

In recent years, the increasing use of power electronics in the commercial and industry processes results in harmonics injection and lower power factor to the electric power system [15]. Conventionally, in order to overcome these problems, passive R-L-C filters have been used. The use of this kind of filters has several disadvantages. Recently, due to the evolution in modern power electronics, new device called “shunt active power filter (SAPF)” was investigated and recognized as a viable alternative to the passive filters[1-3]. The principle operation of the SAPF is the generation of the appropriate current harmonics required by the non-linear load. In fact active filters do not present all the typical drawbacks of passive systems such as the detuning of single tuned filters due to changes of system operative conditions and surrounding environment or the generation of resonance at particular frequencies, between the network and filter reactance, that amplifies unwanted harmonics.

Active power filters are more and more capturing the interest of researchers and industries owing to the decreasing quality of power supplied by the electrical distribution companies and the difficulties in fulfilling the constraints imposed by national and international standards only by using traditional compensating strategies. The use of active systems for compensating harmonic distortion and reactive power in the supply electrical networks, both at user level or at a higher voltage level, is now more often

preferred to the classical passive compensating methods.

In a modern electrical distribution system, there has been a sudden increase of nonlinear loads, such as power supplies, rectifier equipment, domestic appliances, adjustable speed drives (ASD), etc. As the number of these loads increased, harmonics currents generated by these loads may become very significant. These harmonics can lead to a variety of different power system problems including the distorted voltage waveforms, equipment overheating, malfunction in system protection, excessive neutral currents, light flicker, inaccurate power flow metering, etc.

To reduce harmonic distortion and power factor improvement, capacitors are employed as passive filters. But they have the drawback of bulky size, component aging, resonance and fixed compensation performance. These provide either over- or under-compensation of harmonics, whenever a load change occurs [4]. In order to overcome these problems, active power filters (APFs) have been developed. The voltage-source-inverter (VSI)-based shunt active power filter has been used in recent years and recognized as a viable solution [5].

Active filters, besides, permit the control and the compensation of distorted line currents adapting themselves to the load changes and to changing in working frequency. The most effective and the most diffuse structure in active filtering systems is certainly the shunt one composed by an inverter fed by a capacitor and a passive filter used to inject the compensating currents in the grid (Figure 1). In order to overcome these problems, active power filters (APFs) have been developed. The voltage-source-inverter (VSI)-based shunt active power filter has been used in recent years and recognized as a viable solution [5]. The control scheme, in which the required compensating currents are determined by sensing line currents only, is given in [6-11], which is simple and easy to implement. The scheme uses a conventional proportional plus integral (PI) controller for the generation of a reference current template.

2. The active power filter

When linear loads are connected to the supply the waveforms are linear. Whereas non linear loads are connected harmonic appears on electric voltage or current. The harmonics are integer multiples of system frequency. This leads to various power quality problems like heating of the devices, mis-triggering of the drives, pulsating output in the motors, etc., a harmonic filter are used to eliminate the harmonics. There are three basic types of harmonics filters given below.

2.1 Passive power filters (PPF)

It is a type of filter, which consists of only passive components. It consists of linear elements like resistors, capacitors and inductors. They are also called as LC filters, which produce series resonance or parallel resonance that forms a major drawback of this type of filter. Another drawback of PPF is the cost which increases as the voltage rating of the inductor and capacitor increases.

2.2 Active power filter (APF)

APF is a type of filter that uses either current or voltage source as its major component. They compensate voltage or current harmonics by injecting the negative of the harmonic signal measured injected signals fed are of same magnitude but in phase opposition with the measured harmonic signals. It is controlled to draw/supply a compensated current from/to the utility, such that it eliminates reactive and harmonic currents of the non-linear load. Thus, the resulting total current drawn from the ac mains is sinusoidal. Ideally, the APF needs to generate just enough reactive and harmonic current to compensate the non-linear loads in the line [12].

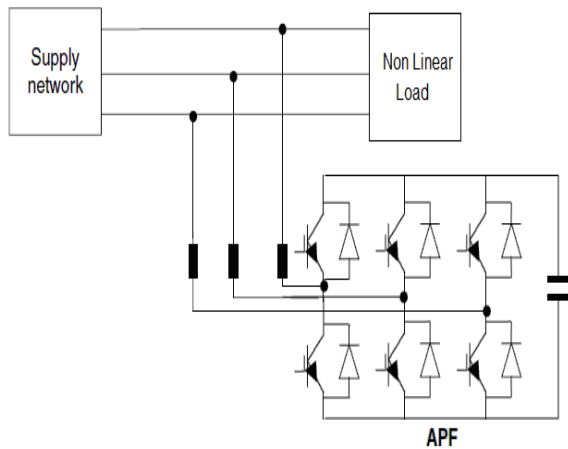

Figure 1 Active power filter connected with transmission line

3. Active filter control scheme

3.1 PI Control scheme

Figure 2 shows the active power filter compensation system with PI control scheme. In order to implement the control algorithm of a shunt active power filter, the DC capacitor voltage (V_{dc}) is sensed and compared with the reference value (V_{dcref}). The Input of PI controller is the value of Error, $e = V_{dcref} - V_{dc}$, and its output, after a limit, is considered as the magnitude of peak reference current I_{max} . The switching signal for the PWM converter are obtained from comparing the actual source currents (i_{sa} , i_{sb} , i_{sc}) with the reference current templates (I_{sa} , I_{sb} , I_{sc}) in a hysteresis current controller. The output pulses are applied to the switching devices of the PWM converter [13-14].

Since coefficients of PI controller, K_p and K_i , are fixed in this model, the performance of active power filter under random load variation conditions is not as well as 'fixed load' condition.

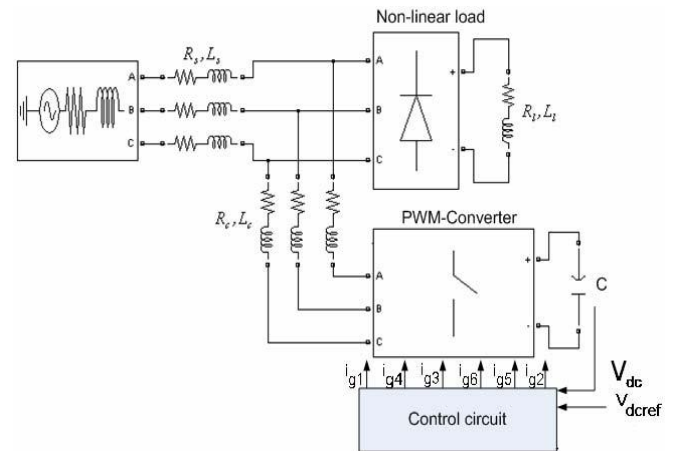

Figure 2 (a) Active filter system

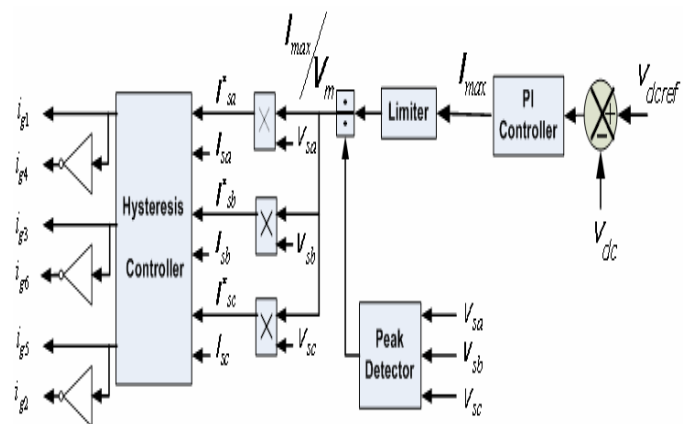

Figure 2 (b) Active filter system using PI controller

4. Simulink model of active power filter

Figure 3 shows the block diagram of PI/Fuzzy controller used for the controlling of active power filter.

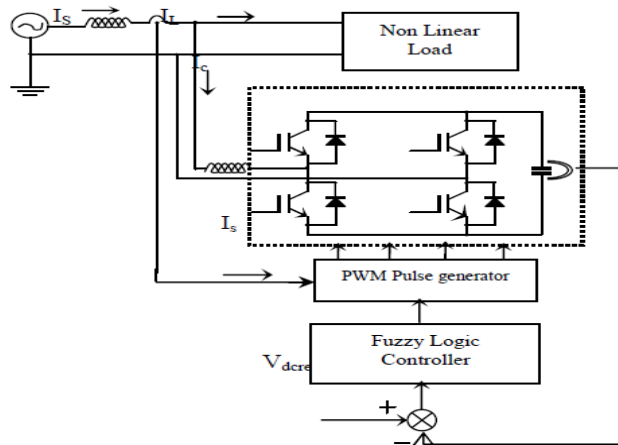

Figure 3 Block diagram of PI/Fuzzy controlled improved power quality converter

The simulation is done using MATLAB for the fuzzy logic controlled voltage source PWM rectifier. The complete rectifier system is composed of mainly (1) three phase source, (2) voltage source PWM rectifier, (3) fuzzy controller, and (4) hysteresis controller.

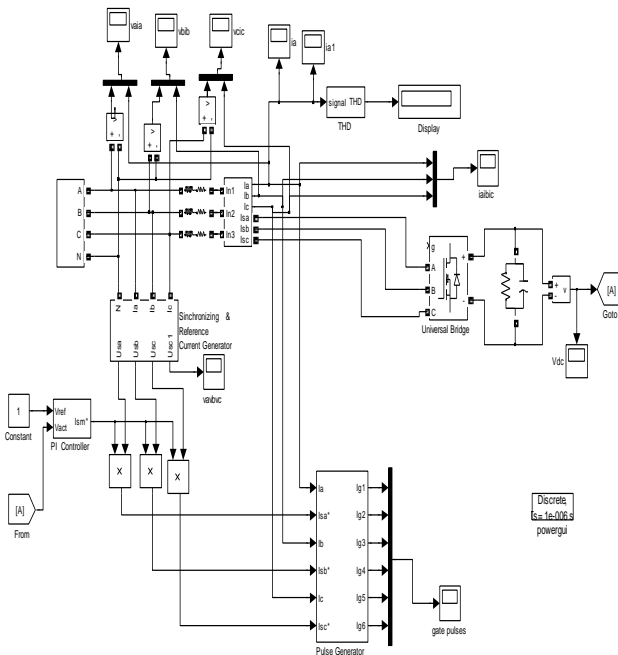

Figure 4 Simulated power circuit without controlled improved power quality converter

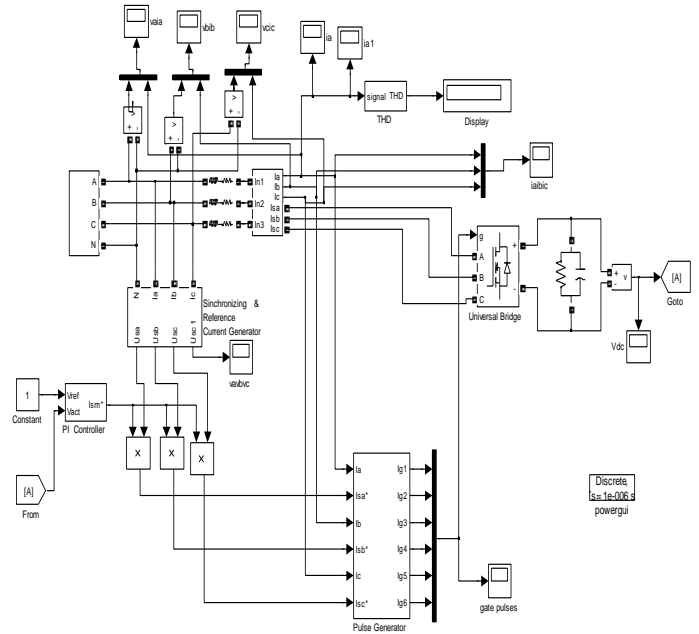
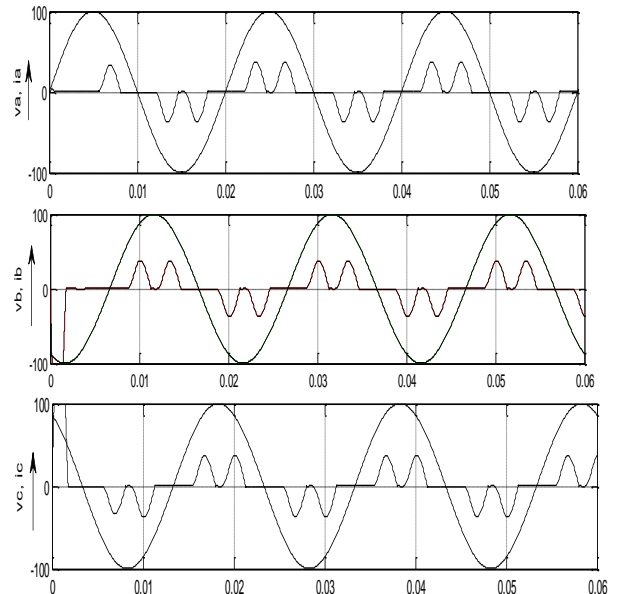

Figure 5 Simulated power circuit for PI controlled improved power quality converter

5. Simulation results

The current and voltage waveform of the conventional three phase rectifier without controller is shown in Figure 6. The current waveform for one cycle and its harmonica spectrum is shown in Figure 7 and 8. The current is non sinusoidal and total harmonica distortion (THD) is very high (88.84%). To make the current sinusoidal and THD within permissible limit current controller is used.



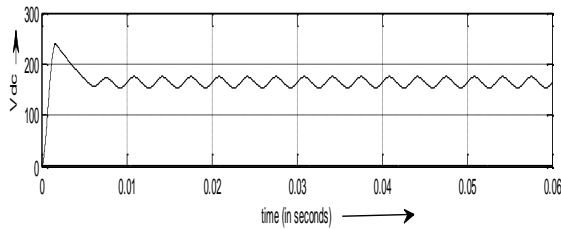

Figure 6 Waveform without controller

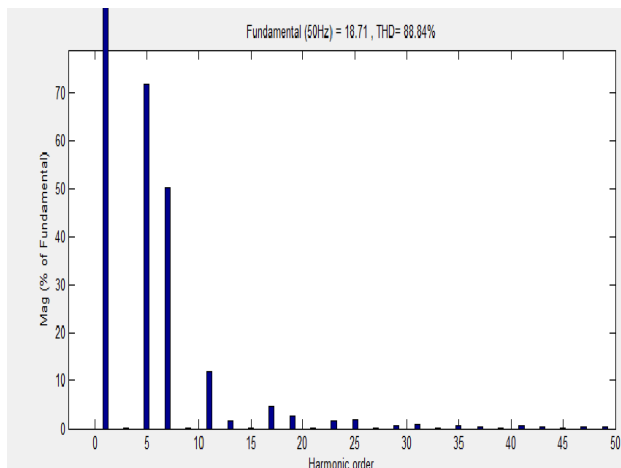

Figure 7 Harmonics spectrum without controller

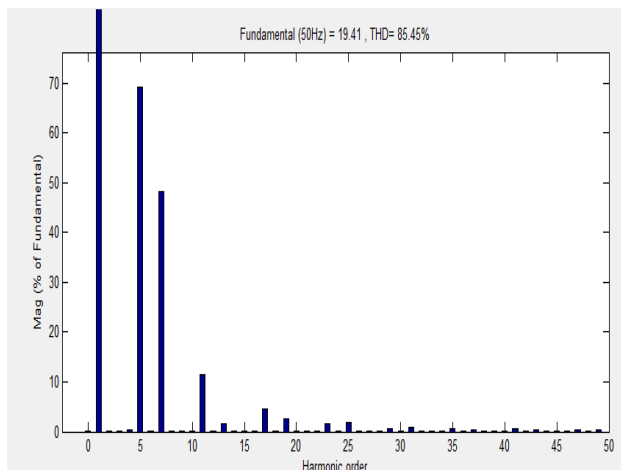

Figure 8 Harmonics spectrum with PI controller

Table 1 Comparative analysis of THD By using various controllers

S.No.	Name of controller	THD (%)
1	Without controller	88.84
2	With PI controller	85.47

6. Conclusion

Based on the simulation results, it can be concluded that, PI controlled PWM rectifier perform satisfactory for the compensation of line current. After

compensation, line current become sinusoidal, balanced and in phase with the respective source voltage and reduces the THD of the source current below 5% limit. It is clear from simulation result that the transient performance of the source current and DC side capacitor voltage is better for the PI controller in term of the setting time and % rise/fall in DC link voltage.

References

- [1] Singh GK, Singh AK, Mitra R. A simple fuzzy logic based robust active power filter for harmonics minimization under random load variation. *Electric Power Systems Research*. 2007; 77(8):1101-11.
- [2] Grady WM, Samotyj MJ, Noyola AH. Survey of active power line conditioning methodologies. *IEEE Transactions on Power Delivery*. 1990;5(3):1536-42.
- [3] Wagner VE, Balda JC, Griffith DC, McEachern A, Barnes TM, Hartmann DP, Phileggi DJ, Emmanuel AE, Horton WF, Reid WE, Ferraro RJ. Effects of harmonics on equipment. *IEEE Transactions on Power Delivery*. 1993;8(2):672-80.
- [4] Singh, Ambrish Chandra, Kamal Al-Haddad B. Computer-aided modeling and simulation of active power filters. *Electric Machines & Power Systems*. 1999;27(11):1227-41.
- [5] Chatterjee K, Fernandes BG, Dubey GK. An instantaneous reactive volt-ampere compensator and harmonic suppressor system. *IEEE Transactions on Power Electronics*. 1999; 14(2):381-92.
- [6] Jain SK, Agarwal P. Design simulation and experimental investigations, on a shunt active power filter for harmonics, and reactive power compensation. *Electric Power Components and Systems*. 2003;31(7):671-92.
- [7] Bose BK. Expert system, fuzzy logic, and neural network applications in power electronics and motion control. *Proceedings of the IEEE*. 1994; 82(8):1303-23.
- [8] Raviraj VS, Sen PC. Comparative study of proportional-integral, sliding mode, and fuzzy logic controllers for power converters. *IEEE Transactions on Industry Applications*. 1997; 33(2):518-24.
- [9] Dell'Aquila A, Lecci A, Monopoli VG. Fuzzy controlled active filter driven by an innovative current reference for cost reduction. In 2002 IEEE international symposium on industrial electronics, ISIE 2002 2002 (pp. 948-952). Institute of Electrical and Electronics Engineers.
- [10] Momoh JA, Ma XW, Tomsovic K. Overview and literature survey of fuzzy set theory in power systems. *IEEE Transactions on Power Systems*. 1995;10(3):1676-90.
- [11] Singh GK, Singh AK, Mitra R. A simple fuzzy logic based robust active power filter for harmonics minimization under random load variation. *Electric Power Systems Research*. 2007; 77(8):1101-11.
- [12] Duffey CK, Stratford RP. Update of harmonic standard IEEE-519: IEEE recommended practices and

- requirements for harmonic control in electric power systems. *IEEE Transactions on Industry Applications*. 1989;25(6):1025-34.
- [13] Bhende CN, Mishra S, Jain SK. TS-fuzzy-controlled active power filter for load compensation. *IEEE Transactions on Power Delivery*. 2006; 21(3):1459-65.
- [14] Elmitwally A, Abdelkader S, Elkateb M. Performance evaluation of fuzzy controlled three and four wire shunt active power conditioners. In *Power Engineering Society Winter Meeting, 2000. IEEE 2000 Jan 23* (pp. 1650-5). IEEE.
- [15] Emanuel AE. Summary of IEEE standard 1459: definitions for the measurement of electric power quantities under sinusoidal, nonsinusoidal, balanced, or unbalanced conditions. *IEEE Transactions on Industry Applications*. 2004; 40(3):869-76.